

SKI-1310-20 Series



LC

1.25

20KM

1.25Gbps SFP Optical Transceiver, 20Km



- SFP package with LC connector ◦
- 1310nm FP laser and PIN photo detector ◦
- Up to 20Km transmission on SMF ◦
- +3.3V single power supply ◦
- LVPECL compatible data input/output interface ◦
- Low EMI and excellent ESD protection ◦
- laser safety standard IEC-60825 compliant ◦
- Compatible with RoHS ◦

Application

- Ethernet
- Telecom
- Fiber Channel

Absolute Maximum Ratings

Parameter	Symbol	Minimum	Maximum	Units
Storage Temperature	Tst	-40	+85	°C
Supply Voltage	Vcc	0	+3.6	V
Operating Relative Humidity	RH	5	95	%

Operation Environment

Parameter		Symbol	Min	Typical	Max	Units
Supply Voltage		Vcc	3.15	3.3	3.45	V
Operating Case Temperature	Commercial	Tc	-10		+70	°C
	Industrial		-40		+85	
Power Dissipation					1	W
Data Rate				155		Mbps





1.25Gbps SFP Optical Transceiver, 20Km

Optical Characteristics

(Ambient Operating Temperature 0°C to +70°C, Vcc =3.3 V)

Parameter	Symbol	Min.	Typ.	Max.	Units
Transmitter Section					
Center Wavelength	λ_o	1270	1310	1350	nm
Spectral Width(RMS)	$\Delta\lambda$	-	-	4	nm
Average Output Power	Po	-8	-	-3	dBm
Extinction Ratio	Er	9	-	-	dB
Rise/Fall Time(20%~80%)	Tr/Tf			0.26	ns
Total jitter	Tj			0.43	UI
Optical Eye Diagram	IEEE 802.3z and ANSI Fibre Channel Compatible				
Receiver Section					
Center Wavelength	λ_o	1270	1310	1610	nm
Receiver Sensitivity	Rsen			-32	dBm
Receiver Overload	Rov	-3			dBm
Return Loss		12			dB
LOS Assert	LOSA	-40			dBm
LOS Dessert	LOSD			-35	dBm
LOS Hysteresis		0.5		4	

Electrical Characteristics

(Ambient Operating Temperature 0°C to +70°C, Vcc =3.3 V)

Parameter	Symbol	Min.	Typ.	Max.	unit
Transmitter Section					
Input Differential Impedence	Zin	90	100	110	Ohm
Data Input Swing Differential	Vin	500		2400	mV
TX Disable	Disable	2.0		Vcc	V
	Enable	0		0.8	V
TX Fault	Assert	2.0		Vcc	V
	Deassert	0		0.8	V
Receiver Section					
Output differential impedance	Zout		100		Ohm
Data Input Swing Differential	Vout	370		2000	mV
Rx_LOS	Assert	2.0		Vcc	V
	Deassert	0		0.8	V



SKI-1310-20 Series



LC

1.25

20KM

1.25Gbps SFP Optical Transceiver, 20Km

EEPROM INFORMATION (A0)

Addr	Field Size (Bytes)	Name of Field	HEX	Description
0	1	Identifier	03	SFP
1	1	Ext. Identifier	04	MOD4
2	1	Connector	07	LC
3-10	8	Transceiver	00 00 00 02 12 00 0D 01	Transmitter Code
11	1	Encoding	01	8B10B
12	1	BR, nominal	0D	1250M bps
13	1	Reserved	00	
14	1	Length (9um)-km	14/28	20km/40km
15	1	Length (9um)	64/C8/FF	
16	1	Length (50um)	37	550m
17	1	Length (62.5um)	37	550m
18	1	Length (copper)	00	
19	1	Reserved	00	
20-35	16	Vendor name	57 49 4E 54 4F 50 20 20 20 20 20 20 20 20 20 20	SUNKIND
36	1	Reserved	00	
37-39	3	Vendor OUI	00 00 00	
40-55	16	Vendor PN	xx xx xx xx xx xx xx xx	ASC II
56-59	4	Vendor rev	31 2E 30 20	V1.0
60-61	2	Wavelength	05 1E	1310nm
62	1	Reserved	00	
63	1	CC BASE	XX	Check sum of byte 0~62
64-65	2	Options	00 1A	LOS, TX_DISABLE, TX_FAILT
66	1	BR, max	32	50%
67	1	BR, min	32	50%
68-83	16	Vendor SN	00 00 00 00 00 00 00 00	Unspecified
84-91	8	Vendor date code	XX XX XX 20	Year, Month, Day
92-94	3	Reserved	00	
95	1	CC EXT	XX	Check sum of byte 64~94
96-255	160	Vendor specific		

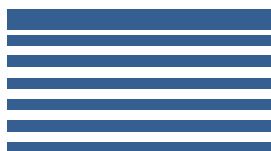



1.25Gbps SFP Optical Transceiver, 20Km

Pin Description

Pins	Name	Description	NOTE
1	VeeT	Transmitter Ground	
2	Tx Fault	Transmitter Fault Indication	1
3	Tx Disable	Transmitter Disable	2
4	MOD DEF2	Module Definition 2	3
5	MOD DEF1	Module Definition 1	3
6	MOD DEF0	Module Definition 0	3
7	Rate Select	Not Connected	
8	LOS	Loss of Signal	4
9	VeeR	Receiver Ground	
10	VeeR	Receiver Ground	
11	VeeR	Receiver Ground	
12	RD-	Inv. Received Data Output	5
13	RD+	Received Data Output	5
14	VeeR	Receiver Ground	
15	VccR	Receiver Power	
16	VccT	Transmitter Power	
17	VeeT	Transmitter Ground	
18	TD+	Transmit Data Input	6
19	TD-	Inv. Transmit Data Input	6
20	VeeT	Transmitter Ground	

Notes:

- TX Fault is an open collector output, which should be pulled up with a $4.7k\sim 10k\Omega$ resistor on the host board to a voltage between 2.0V and $V_{cc}+0.3V$. Logic 0 indicates normal operation; logic 1 indicates a laser fault of some kind. In the low state, the output will be pulled to less than 0.8V.
- TX Disable is an input that is used to shut down the transmitter optical output. It is pulled up within the module with a $4.7k\sim 10k\Omega$ resistor. Its states are: Low (0~0.8V): Transmitter on (>0.8V, <2.0V): Undefined High (2.0~3.3V): Transmitter Disabled Open: Transmitter Disabled
- MOD-DEF 0,1,2 are the module definition pins. They should be pulled up with a $4.7k\sim 10k\Omega$ resistor on the host board. The pull-up voltage shall be V_{ccT} or V_{ccR} .
MOD-DEF 0 is grounded by the module to indicate that the module is present
MOD-DEF 1 is the clock line of two wire serial interface for serial ID MOD-DEF 2 is the data line of two wire serial interface for serial ID
- LOS is an open collector output, which should be pulled up with a $4.7k\sim 10k\Omega$ resistor on the host board to a voltage between 2.0V and $V_{cc}+0.3V$. Logic 0 indicates normal operation; logic 1 indicates loss of signal. In the low state, the output will be pulled to less than 0.8V.
- These are the differential receiver output. They are internally AC-coupled 100 Ω differential lines which should be terminated with 100 Ω (differential) at the user SERDES.
- These are the differential transmitter inputs. They are AC-coupled, differential lines with 100 Ω differential termination inside the module.



SKI-1310-20 Series



LC

1.25

20KM

1.25Gbps SFP Optical Transceiver, 20Km

Recommended Application Circuit

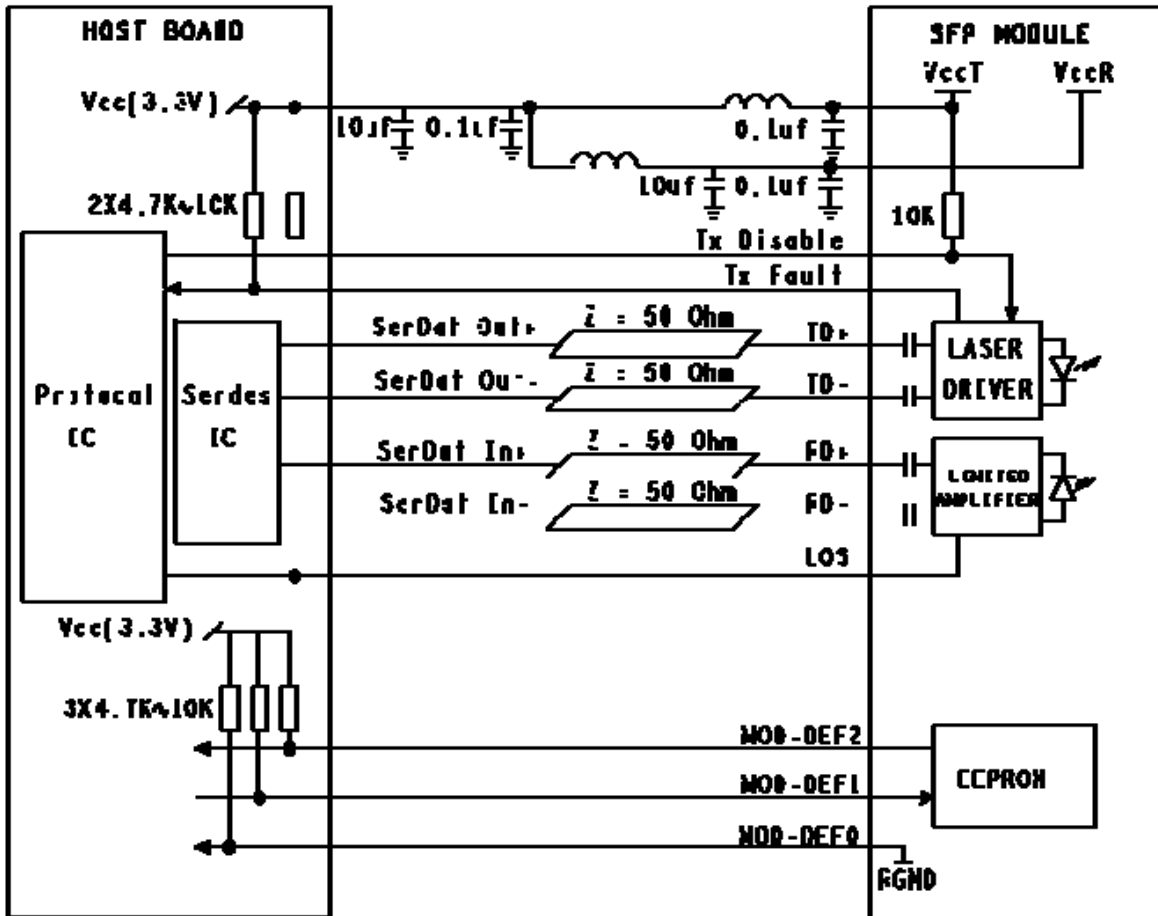

Outline drawing(mm)

